

METALLIC Creations

INSTALLATION GUIDE

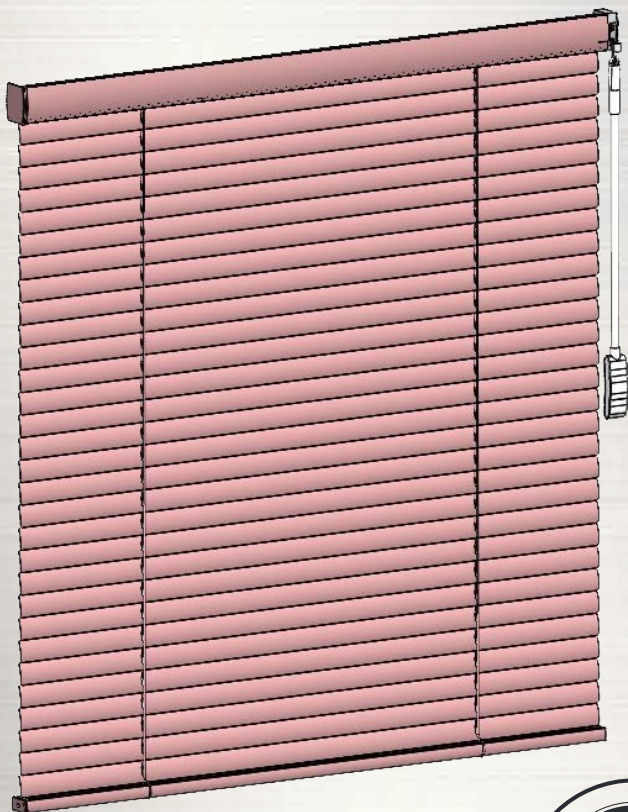

Lift Control:

MOTORIZED



CONTENTS

INCLUDED IN YOUR PACKAGE	1
SUGGESTED TOOLS (NOT INCLUDED)	2
MOUNTING OPTIONS	3
MOUNTING BRACKETS	4
INSTALLING THE BLINDS	6
MOTORIZED WAND	7
CONFIGURING YOUR BLINDS	9
CARE AND CLEANING	11
WARNING	12
EMERGENCY / FIRST AID	12

Thank you for Choosing our Metallic Creations Blinds for your Residential or Commercial Property.

We are confident that you will find our Metallic Creations Blinds to be of superior quality and value, compared to other blinds available.

In this guide, you will find useful information about installation, child safety, cleaning, and warranty when using your blinds.

READ ALL INSTALLATION INSTRUCTIONS BEFORE INSTALLING

CONTACTING US:

Contact your Dealer regarding any question or concerns about your product.

PLEASE KEEP FOR FUTURE REFERENCE / TROUBLESHOOTING

INCLUDED IN YOUR PACKAGE

1" MINI BLINDS

MOTORIZED WAND

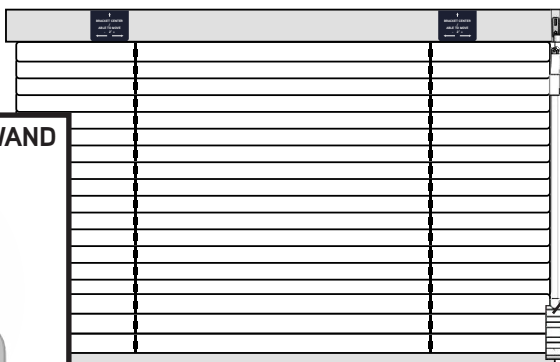

MOTORIZED
WAND

SCREWS

Quantity: 4 per packet



CHARGING BRICK / MICRO USB

Quantity: 1 (10' cable provided) per blind

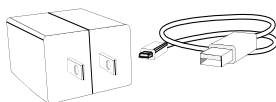

BRACKETS

Quantity: 2

The wider the blinds the more brackets provided - see chart below

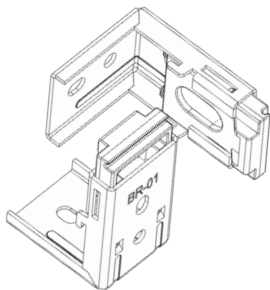

INSTALLATION BRACKET REQUIREMENT CHART

Blinds Width	Brackets Required
39" or smaller	2
40" to 59"	3
60" to 78"	4
79" to 98"	5

OPTIONAL PARTS:

(supplied upon request)

Spacer Blocks (Not Provided)

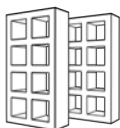

Use for shades that need more space between the wall.

Wall anchors (Not Provided).

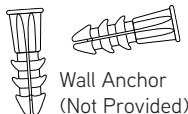

Wall Anchor
(Not Provided)

If mounting into drywall, you will need wall anchors to ensure a secure installation.

SUGGESTED TOOLS (NOT INCLUDED)

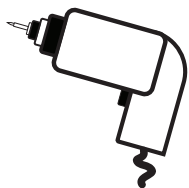

DRILL

*3/32" drill bit,
and 1/4"
hex driver*

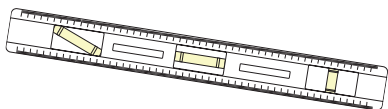

LEVEL



PENCIL



SCREWDRIVER

*Flat blade, Phillips, or
1/4" hex driver*

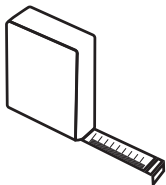

TAPE MEASURE

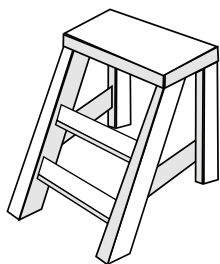

LADDER

MOUNTING OPTIONS

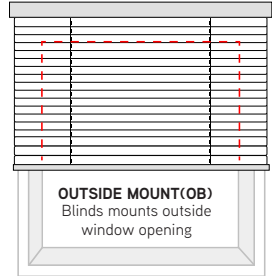
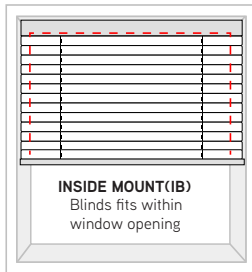
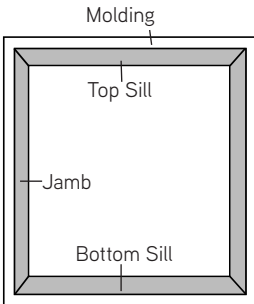

Your new blinds are custom made to your specifications. The installation should be easy and your blinds will look elegant.

MOUNTING NOTES:

Mounting screws provided are suitable for most mounting surfaces. See below for additional suggestions.

- **For wallboard or plaster:**

Use hollow wall anchors for added support. (not included)

- **For concrete, stone, brick or tile:**

Use an appropriate drill and appropriate anchors before fastening the screws. (not included)

- **For metal surfaces:**

Pre-drill holes and use appropriate drill and appropriate anchors before fastening the screws. (not included)

INSIDE MOUNT: Top of bracket

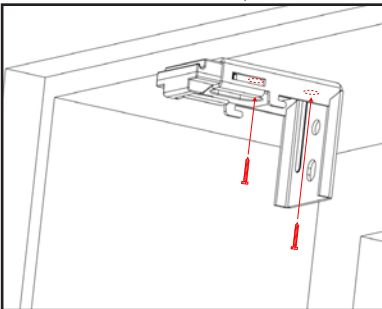

OUTSIDE MOUNT: Back of bracket

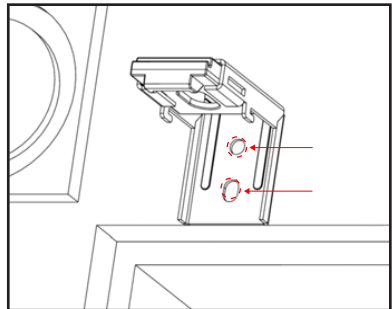

Inside Mount Depth Requirements

Bracket	Minimum Depth	Fully Recessed*	Fully Recessed*
		1-1/2" Depth Headrail	2-1/2" Depth Headrail
Standard	1-1/8"	2-1/2"	2-1/2"
Ceiling	1-1/8"	2-1/2"	2-1/2"
Extension	1-7/8"	1-1/8"	3-1/2"

Outside Mount Surface Space Requirements

Bracket	Minimum Depth
Standard	1-1/8"
Ceiling	1-1/8"
Extension	1-1/4"

1 MOUNTING BRACKETS | Illustration

Installing Brackets:

Inside mount: Use the stickers on the headrail to find the bracket center for each bracket. The bracket is able to move within the 2" area shown on the sticker.

- Hold the headrail up inside the window frame and mark center based of the provided stick on the headrail.

Inside Mount

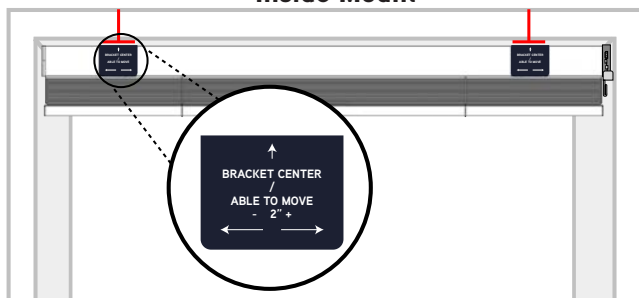

- Align brackets to the marked positions and secure through two holes, ensuring that the bracket tops are aligned and level to one another. Use wall anchors for a secure hold.

To ensure proper blinds operation, mount the brackets level.

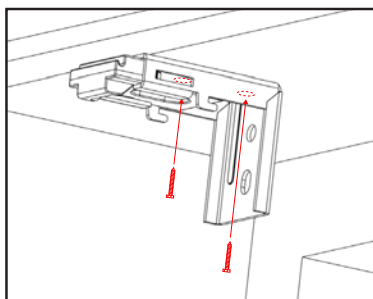
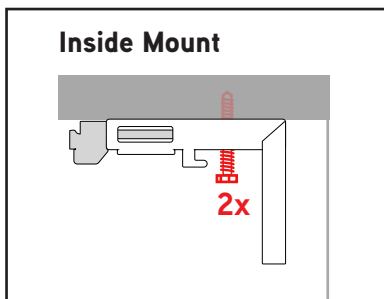
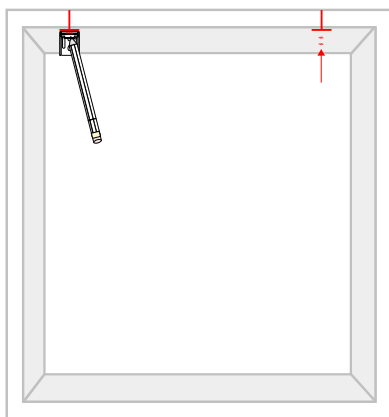
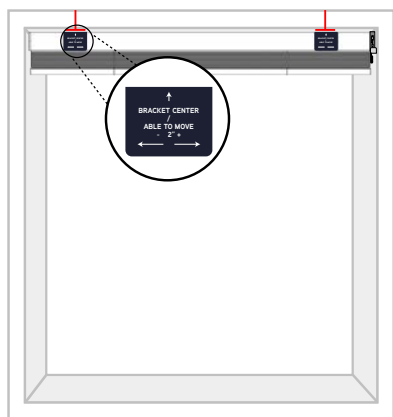

Spacer blocks (optional) will be attached to the end of each bracket. Ensure screws are long enough to secure brackets with spacer blocks. Do not use more than three spacer blocks per bracket. If installing extension brackets, do not use spacer blocks.

Outside Mount: Outside edge of the brackets should be positioned at a minimum of 2" from the outside of the headrail cassette, note the sticker on the headrail cassette. Use wall anchors for a secure hold. Mark the position of the bracket as illustrated.

- Hold the headrail up above outside the window frame and mark center based of the provided sticker on the headrail.

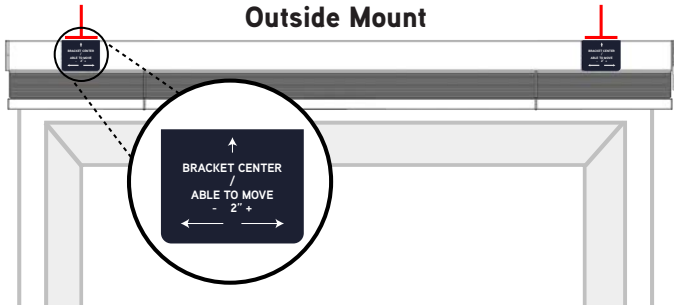

- Align brackets to the marked positions and secure through two holes, ensuring that the bracket tops are aligned and level to one another. Use wall anchors for a secure hold.

To ensure proper blinds operation, mount the brackets level.

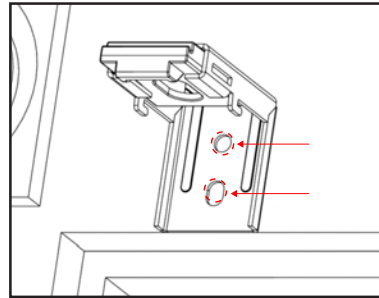
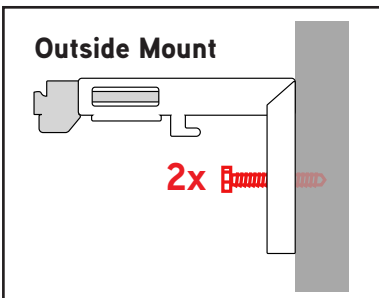
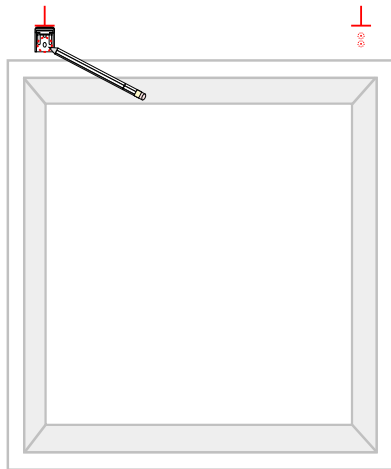
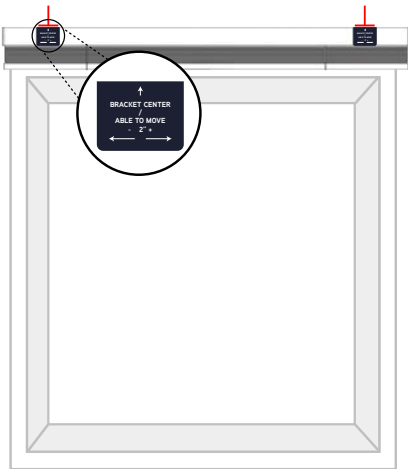
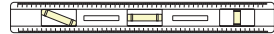

Spacer blocks (optional) will be attached to the end of each bracket. Ensure screws are long enough to secure brackets with spacer blocks. Do not use more than three spacer blocks per bracket. If installing extension brackets, do not use spacer blocks.

2

INSTALLING THE BLINDS | Illustration

1. Lift the head rail into position

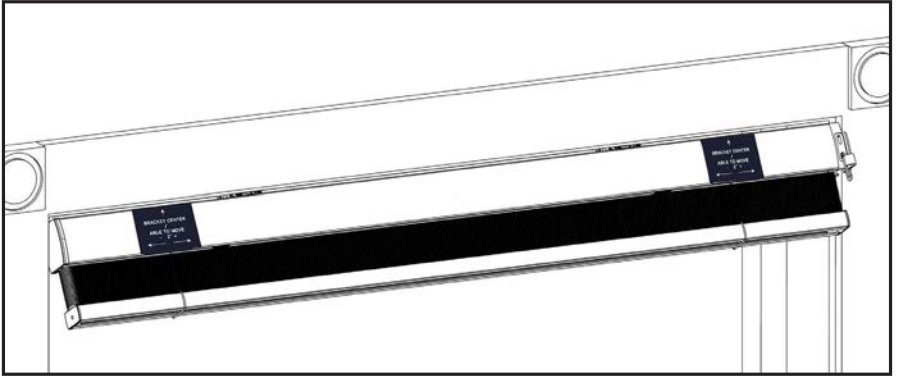

2. Slide the headrail into the brackets and rotate it down until it snaps into place.

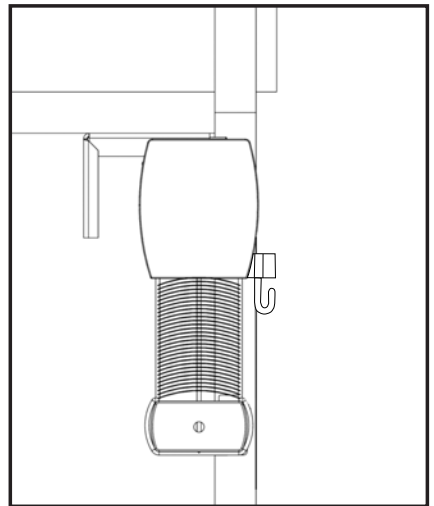
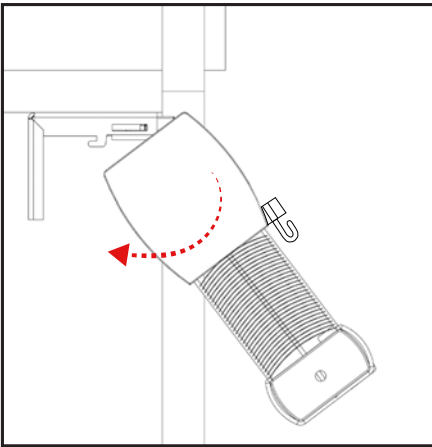

3 MOTORIZED WAND | Illustration

- Before the use of the blinds, make sure the wand is attached to the headrail. If it is not, unpack the wand and hook onto the provided location.
- Plug the micro USB into the port at the end of the headrail.

Attach the Motorized Wand

1. Attach the hoop end of the wand to the hook on the headrail.

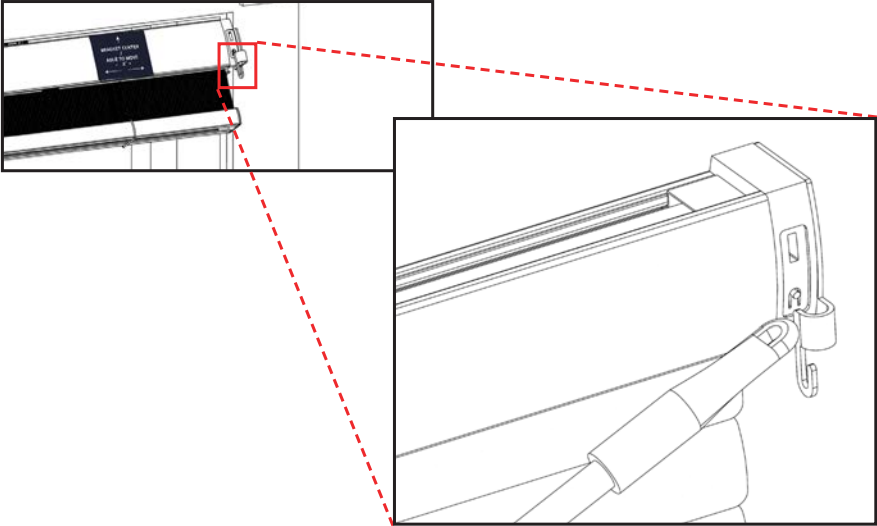

2. Attach the usb cable to the headrail.
3. Attach end cap.

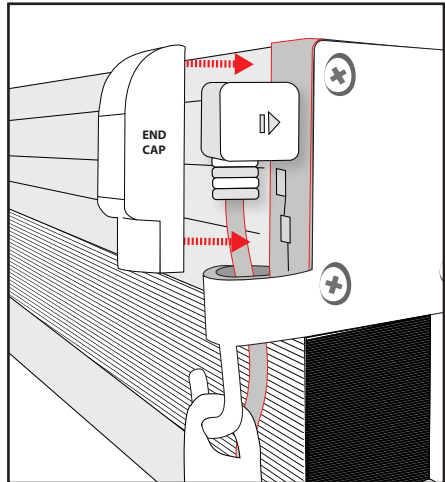
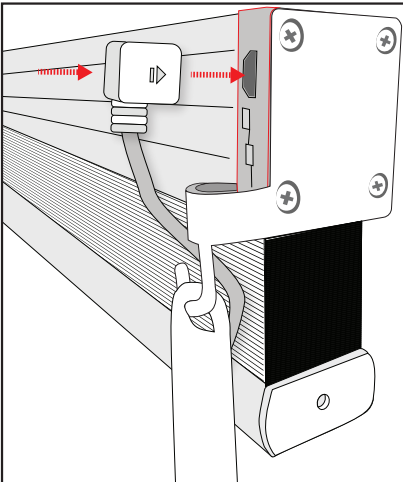

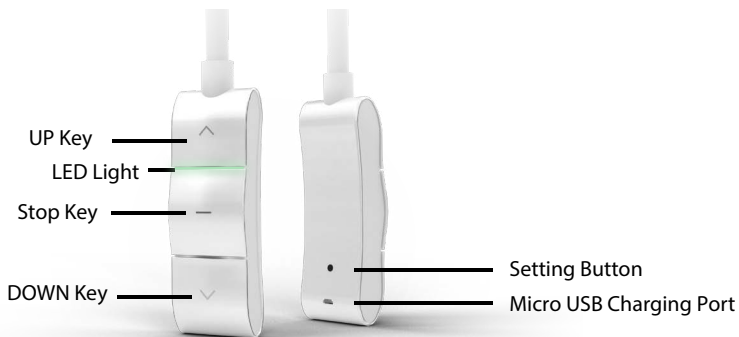

MOTORIZED WAND

NOTE:

We suggest that you charge the blinds prior to installation.

- It is suggested to charge the battery overnight (7 hours for a full charge)
- Before continued use of the blinds. Use the USB cable that comes provided to charge the blinds.
- This cable can be plugged into the back of the wand at any time to charge the blinds. The blinds are functional while in charging mode.

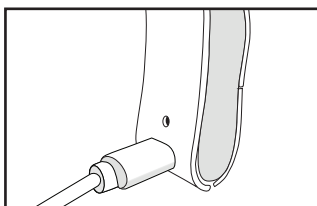
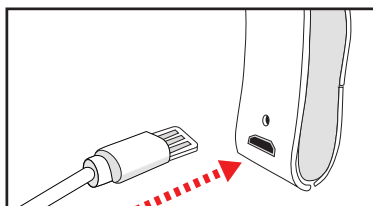

NOTICE: ALL SHADES COME PRE-PROGRAMMED FROM THE FACTORY. THIS GUIDE SERVES AS A TROUBLESHOOTING AID. IF THE CONSUMER RESETS THE PROGRAMMING, TECHNICAL SUPPORT WILL BE AT THE DESCRETION OF THE MANUFACTURER.

CHARGING THE MOTORIZED WAND

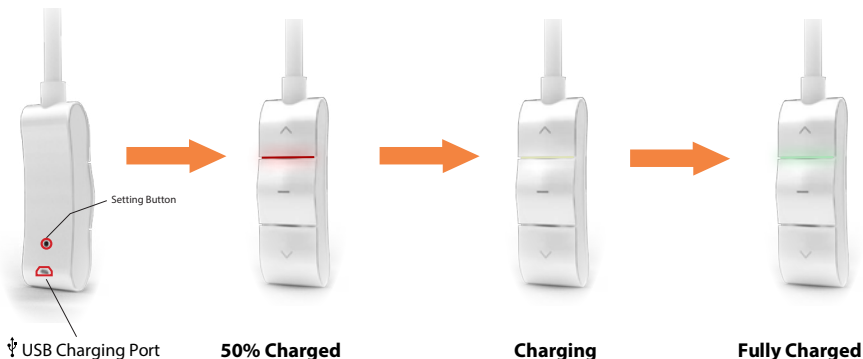

4 CONFIGURING YOUR BLINDS | Illustration

NOTE:

- If your blinds are not functioning properly, check the connection between the wand, motor, and battery.
- If the motor isn't running properly the limit setting needs to be reset.
- Please use a paper clip to press the **SETTING** button on the back of the wand to perform many of the steps below.

Changing Direction

This process requires setting both the top height and the bottom height back to back for the process to function properly.

1. Press the **UP** button to determine if the direction needs to be changed. If the motor goes up, do nothing. If the motor goes down, continue to the next step.

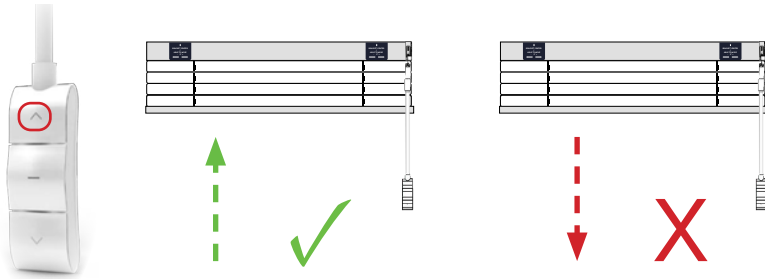

2. Using the paper clip press and hold the **SETTING** button and the **STOP** button. Release both buttons when the motor beeps.

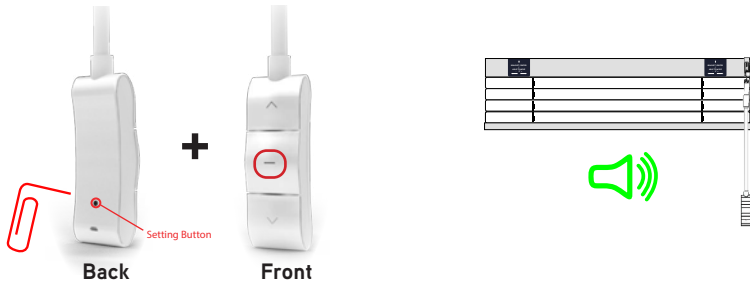

3. Press the **UP** button. If the motor goes up, the rotation direction has been reversed.

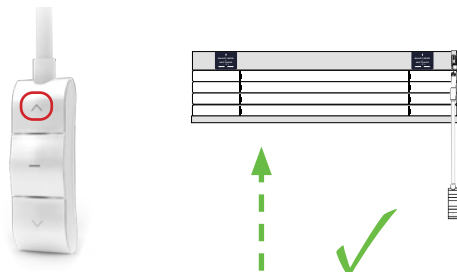

Setting Lift Heights

This process requires setting both the top height and the bottom height back to back for the process to function correctly.

Bottom Height Setting

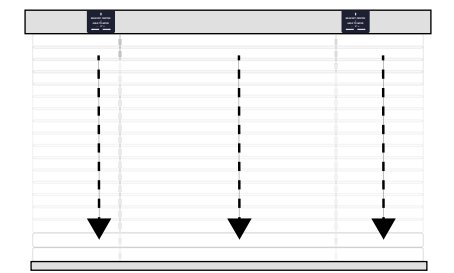

1. Press and hold the **SETTING** button on the back of the wand. Release when the motor beeps.
2. Press the **DOWN** button. The motor will descend down. Press the **STOP** button at the desired bottom height.
3. Use **UP** or **DOWN** to make any small adjustments for the final bottom position.
4. Press the **SETTING** button. The motor will beep indicating the bottom height has been set.

Top Height Setting (Immediately After Setting Bottom Height):

1. Press the **UP** button. The motor will begin to rise.
2. Press the **STOP** button at the desired top height.
3. Press the **UP** and **DOWN** buttons to make any small adjustments for the final top position.
4. Press the **SETTING** button. The motor will beep indicating the top height has been set.

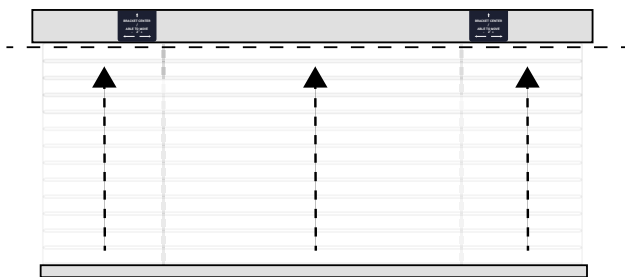

Setting a Favorite Position

1. Press the **UP** and **DOWN** button to move the blinds toward your desired favorite position. Press the **STOP** button once the position is reached.
2. Press and hold the **SETTING** and **UP** buttons until you hear the motor beep. The favorite position is now set.
3. Press and hold **STOP** button until the shade begins to full move. The motor will take the blinds to the favorite position from any starting point.

CARE AND CLEANING

Remove The Blinds

1. Fully raise the blinds.

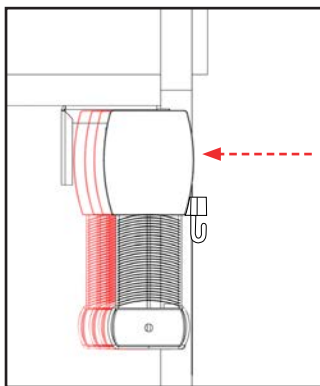

2. While holding the headrail, push in towards the brackets and then rotate towards yourself.

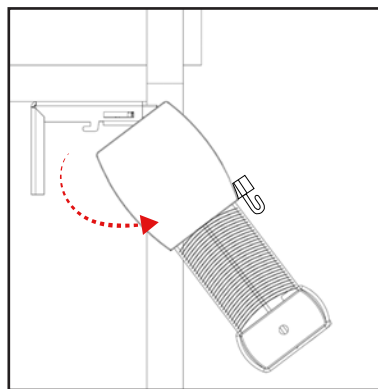

3. Rotate towards yourself to remove.

Cleaning Procedures

The following options are available if your blinds needs cleaning.

Dust Removal

In most cases, just use a feather duster to gently dust off regularly.

Vacuuming

Use a low-suction hand-held vacuum cleaner to remove dust more thoroughly.

Hair Dryer

Use a hair dryer to turn on the cold air to blow away the dirt and debris between the blades.

Spot Cleaning

- Dampen a clean cloth and wring out, then wipe them down.
- Allow the blinds to dry in the completely lowered position.

NOTE:

The Warning labels on the bottom-rails of corded window coverings contain important safety information. These warning labels are designed to be permanent, in accordance with the industry's safety standards, and must not be removed.



WARNING

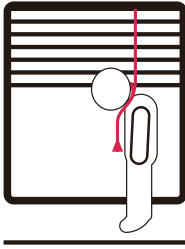

WINDOW BLIND CORD STRANGULATION RISK:

A damaged, loose, or missing tension device poses a strangulation risk to children. Remove from the use and repair or replace if tension device is damaged, loose, or missing.

IMPORTANT SAFETY WARNING:

Window cords can pose a potential strangulation hazard to young children. According to the U.S. Consumer Product Safety Commission, corded window coverings are among the top five hidden hazards in American homes. Check your window coverings for exposed or dangling cords and retrofit or replace them with today's safer products.

Never place a crib, playpen, bed or any type of low-standing furniture near a window. In exploring their surroundings, young children can accidentally fall through an open window or window screen, or become tragically entangled in a nearby window cord. Whenever possible, place cribs and furniture on a non-windowed wall.

Dangling or accessible cords on window coverings can pose an accidental strangulation hazard to infants and young children. For your safety, replace older corded window coverings with today's safer products.

The Window Covering Safety Council (WCSC) and government safety officials recommend that you only use cordless window products in homes with young children.

CHOKING HAZARD:



- Keep cord out of reach from children.
- Remove objects below window.
- Do not tie cords together.
- Make sure safety cords are located 1-2 inches below the headrail.
- Please reference all warning tags in the instructions and on the shade.
- Please keep cords out of children and pets reach, a cord cleat or a cord tensioner device can be found at a local window covering store.



EMERGENCY / FIRST AID

- Remove cord from child's neck
- Call 911 or an Emergency Call Center
- Clear the throat
- Check breathing and heartbeat
- Begin CPR if trained

THIS PRODUCT IS...





M O T O R I Z E D W A R R A N T Y

We offer a 2-year warranty on the Motorized E Series motor and controls. Specifically, we warrant that the Fabric E Series rod motor and control are free from defects in material and workmanship under normal use and suitable for a period of 2 years from the date indicated on each product. If the product fails within this 2-year period, we will repair or replace it free of charge through your final supplier. Batteries are not covered by warranty.

L I M I T E D 3 Y E A R W A R R A N T Y

The Manufacturers Collection will be free from defects in materials and workmanship for as long as the original purchaser owns the product, provided that the product was installed properly. The limited 3-year warranty is extended to the original purchaser only, in the original window for which it was intended.

The warranty does not include any condition or damage resulting from accidents, alterations, misuse, failure to install properly, or other instances outside of Manufacturers control. This warranty also does not apply to conditions resulting from normal wear and tear.

To obtain service, contact the dealer from whom you purchased the product. Manufacturer will repair or replace defective parts or components at no charge.

This warranty is exclusive and in lieu of all other obligations, liabilities or warranties. In no event shall Manufacturers be liable for incidental or consequential damages, or for any other damage, loss or expense, cost or fees associated with such damage. In some states, exclusion for incidental or consequential damages are not allowable.

This warranty does not cover any transport, removal, or re-installation charges which may occur as a result of defects in materials or workmanship.

This warranty gives you specific legal rights, and may also have other rights, which vary from state to state.